

Cisco路由器的路由协议介绍与配置

Dr. Xiqun Lu

College of Computer Science,
Zhejiang University

路由协议

- 生成路由表项通常有两种方法：手工静态设置和动态路由协议生成。
- 动态路由协议主要包括：
 - RIP (Routing Information Protocol)
 - OSPF (Open Shortest Path First,开放式最短路径优先协议)
 - IS-IS (Intermediate System to Intermediate System)
 - BGP(Border Gateway Protocol)

静态路由(Static Routing)

- 静态路由是一种特殊的路由，由网络管理员采用手工方法在路由器中配置而成，这种方法比较适合于规模小，路由表相对简单的网络使用。
- 存在问题：
 - 不能自适应网路拓扑结构的变化
- 命令格式：
 - Router(config)# ip route x1.x2.x3.x4 y1.y2.y3.y4 z1.z2.z3.z4
 - 其中， x1.x2.x3.x4为目标网络的网络地址； y1.y2.y3.y4为目标网络的子网掩码； z1.z2.z3.z4为去目标网络的下一跳IP地址（与本路由器直连那个路由器的接口IP地址）
 - Router(config)# no ip route x1.x2.x3.x4 y1.y2.y3.y4 z1.z2.z3.z4 (删除一条静态路由)
 - Router(config)# ip route 0.0.0.0 0.0.0.0 z1.z2.z3.z4 (默认路由命令方式)
 - Router# show ip route (查看路由表信息)

静态路由-配置实例

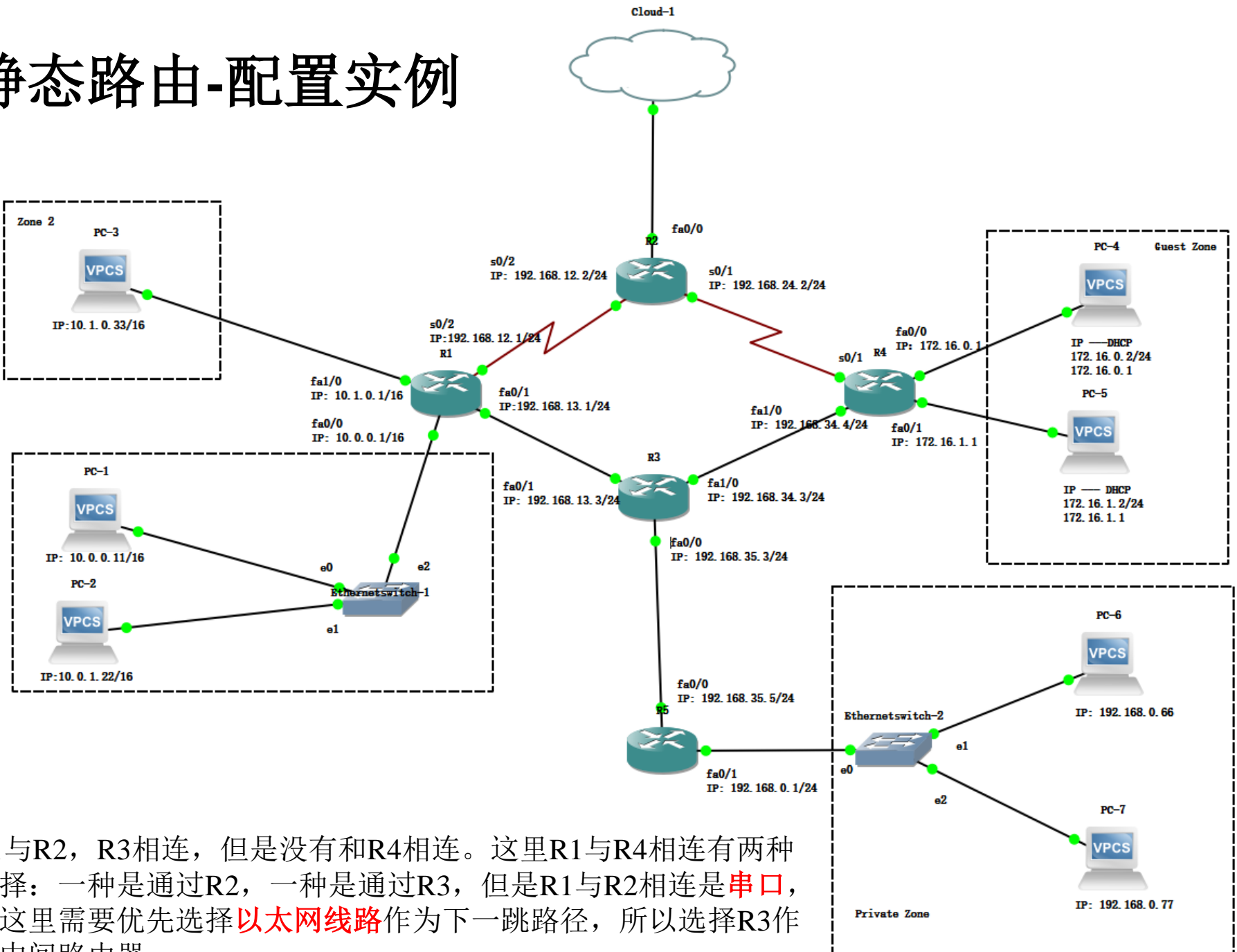

R1与R2, R3相连, 但是没有和R4相连。这里R1与R4相连有两种选择: 一种是通过R2, 一种是通过R3, 但是R1与R2相连是**串口**, 而这里需要优先选择**以太网线路**作为下一跳路径, 所以选择R3作为中间路由器

Static Routing Example: Lab4

The screenshot displays a GNS3 network simulation with four routers (R1, R2, R3, R4) and their configurations. The configurations show static routes being set up between the routers. The IP tables show the resulting routing tables for each router.

R1 Configuration:

```
R1#config t
Enter configuration commands, one per line. End with CNTL/Z.
R1(config)#ip route 172.16.0.0 255.255.255.0 192.168.13.3
R1(config)#ip route 172.16.1.0 255.255.255.0 192.168.13.3
R1(config)#exit
```

R1 IP Table:

```
R1#show ip route
Codes: C - connected, S - static, R - RIP, M - mobile, B - BGP
D - EIGRP, EX - EIGRP external, O - OSPF, IA - OSPF inter area
N1 - OSPF NSSA external type 1, N2 - OSPF NSSA external type 2
E1 - OSPF external type 1, E2 - OSPF external type 2
I - IS-IS, su - IS-IS summary, L1 - IS-IS level-1, L2 - IS-IS level-2
ia - IS-IS inter area, * - candidate default, U - per-user static route
o - ODR, P - periodic downloaded static route

Gateway of last resort is not set

C 192.168.12.0/24 is directly connected, Serial0/0
C 192.168.13.0/24 is directly connected, FastEthernet1/0
  172.16.0.0/24 is subnetted, 2 subnets
S 172.16.0.0 [1/0] via 192.168.13.3
S 172.16.1.0 [1/0] via 192.168.13.3
10.0.0.0/16 is subnetted, 2 subnets
C 10.0.0.0 is directly connected, FastEthernet0/0
C 10.1.0.0 is directly connected, FastEthernet0/1
R1#
```

R2 Configuration:

```
R2#config t
Enter configuration commands, one per line. End with CNTL/Z.
R2(config)#ip route 10.0.0.0 255.255.0.0 192.168.34.4
R2(config)#ip route 10.1.0.0 255.255.0.0 192.168.34.4
R2(config)#exit
```

R2 IP Table:

```
R2#show ip route
Codes: C - connected, S - static, R - RIP, M - mobile, B - BGP
D - EIGRP, EX - EIGRP external, O - OSPF, IA - OSPF inter area
N1 - OSPF NSSA external type 1, N2 - OSPF NSSA external type 2
E1 - OSPF external type 1, E2 - OSPF external type 2
I - IS-IS, su - IS-IS summary, L1 - IS-IS level-1, L2 - IS-IS level-2
ia - IS-IS inter area, * - candidate default, U - per-user static route
o - ODR, P - periodic downloaded static route

Gateway of last resort is not set

C 192.168.13.0/24 is directly connected, FastEthernet1/0
  172.16.0.0/24 is subnetted, 2 subnets
S 172.16.0.0 [1/0] via 192.168.34.4
S 172.16.1.0 [1/0] via 192.168.34.4
10.0.0.0/16 is subnetted, 2 subnets
C 10.0.0.0 [1/0] via 192.168.13.1
C 10.1.0.0 [1/0] via 192.168.13.1
R2#
```

R3 Configuration:

```
R3#config t
Enter configuration commands, one per line. End with CNTL/Z.
R3(config)#ip route 10.0.0.0 255.255.0.0 192.168.13.1
R3(config)#ip route 10.1.0.0 255.255.0.0 192.168.13.1
R3(config)#ip route 172.16.0.0 255.255.255.0 192.168.34.4
R3(config)#ip route 172.16.1.0 255.255.255.0 192.168.34.4
R3(config)#exit
```

R3 IP Table:

```
R3#show ip route
Codes: C - connected, S - static, R - RIP, M - mobile, B - BGP
D - EIGRP, EX - EIGRP external, O - OSPF, IA - OSPF inter area
N1 - OSPF NSSA external type 1, N2 - OSPF NSSA external type 2
E1 - OSPF external type 1, E2 - OSPF external type 2
I - IS-IS, su - IS-IS summary, L1 - IS-IS level-1, L2 - IS-IS level-2
ia - IS-IS inter area, * - candidate default, U - per-user static route
o - ODR, P - periodic downloaded static route

Gateway of last resort is not set

C 192.168.34.0/24 is directly connected, FastEthernet2/0
C 192.168.35.0/24 is directly connected, FastEthernet0/0
  172.16.0.0/24 is subnetted, 2 subnets
S 172.16.0.0 [1/0] via 192.168.34.4
S 172.16.1.0 [1/0] via 192.168.34.4
10.0.0.0/16 is subnetted, 2 subnets
C 10.0.0.0 [1/0] via 192.168.13.1
C 10.1.0.0 [1/0] via 192.168.13.1
R3#
```

R4 Configuration:

```
R4#config t
Enter configuration commands, one per line. End with CNTL/Z.
R4(config)#ip route 10.0.0.0 255.255.0.0 192.168.34.3
R4(config)#ip route 10.1.0.0 255.255.0.0 192.168.34.3
R4(config)#exit
```

R4 IP Table:

```
R4#show ip route
Codes: C - connected, S - static, R - RIP, M - mobile, B - BGP
D - EIGRP, EX - EIGRP external, O - OSPF, IA - OSPF inter area
N1 - OSPF NSSA external type 1, N2 - OSPF NSSA external type 2
E1 - OSPF external type 1, E2 - OSPF external type 2
I - IS-IS, su - IS-IS summary, L1 - IS-IS level-1, L2 - IS-IS level-2
ia - IS-IS inter area, * - candidate default, U - per-user static route
o - ODR, P - periodic downloaded static route

Gateway of last resort is not set

C 192.168.24.0/24 is variably subnetted, 2 subnets, 2 masks
C 192.168.24.0/24 is directly connected, Serial0/1
C 192.168.24.2/32 is directly connected, Serial0/1
  172.16.0.0/24 is subnetted, 2 subnets
S 172.16.0.0 is directly connected, FastEthernet0/0
S 172.16.1.0 is directly connected, FastEthernet0/1
10.0.0.0/16 is subnetted, 2 subnets
S 10.0.0.0 [1/0] via 192.168.34.3
S 10.1.0.0 [1/0] via 192.168.34.3
C 192.168.34.0/24 is directly connected, FastEthernet2/0
R4#
```

路由协议

- 生成路由表项通常有两种方法：手工静态设置和动态路由协议生成。
- 动态路由协议主要包括：
 - **RIP (Routing Information Protocol)**
 - OSPF (Open Shortest Path First,开放式最短路径优先协议)
 - IS-IS (Intermediate System to Intermediate System)
 - BGP(Border Gateway Protocol)

RIP 路由协议 (I)

- RIP (Routing Information Protocol)路由协议采用距离向量算法 (Distance Vector Routing)，主要为小型网络设计的，它显著的特点是配置简单。RIP在计算路由的开销时，只根据经过路由器的跳数，而不考虑链路的带宽，延迟等复杂因素。它的跳计数限制为15个，所以不能适用于具有复杂拓扑结构的网络。
- 命令格式：
 - Router(config)# router rip
 - Router(config-router)#version 2
 - Router(config-router)#network {Network Number}
 - 配置RIP协议时，多个network命令指明了多个网络号，在这些网络号所覆盖的路由器的接口上启用RIP协议，启用RIP协议意味着允许发送和接受RIP路由更新报文信息。
 - Network Number就是指IP地址中网段信息(Network Portion)，如网段7.8.9.0的子网掩码是255.255.255.0，则配置命令为：network 7.8.9.0
 - Router(config-router)#no router rip (删除RIP路由)
 - Router#show ip protocols (查看路由器上路由协议运行情况)
 - Router#show running-config
 - Router#show ip route (查看路由表)

RIP 路由协议 (II)

- RIP从已配置接口发送整个路由表，该表以广播(255.255.255.255)或组播(Multicast，目的地址224.0.0.9)的形式周期性向所有节点发送。
- “路由更新”定时器规定了周期性广播或组播的频率，缺省值定为30秒。
- 如果达到**无效(invalid)**超时时间(缺省为180秒)时，路由器仍未收到某路由器的路由更新信息，将把该条路由标记为无效，认为不可达，**标记为无效的方式就是将跳数设定为16**。
- 被标记为不可达的路由仍将保存在路由表里，直到**清除定时器**超时后，才被清除掉，清除定时器的缺省值为240秒。
- 当某一路由项RI包含的目的网络变成不可达到后，该路由项对应的**抑制定时器**开始计时，在此定时器超时前，即使路由器收到的路由更新指明路由项RI又可达到了，路由项RI仍被本路由器标识为不可到达，只有在抑制定时器超时后，指明路由项RI可到达的路由更新才起作用。抑制定时器的目的在于使路由稳定，不要发生路径摇摆。

RIP 路由协议 (III)

 R1

```
R1#  
R1#show ip protocols  
Routing Protocol is "rip"  
  Outgoing update filter list for all interfaces is not set  
  Incoming update filter list for all interfaces is not set  
  Sending updates every 30 seconds, next due in 24 seconds  
  Invalid after 180 seconds, hold down 180, flushed after 240  
  Redistributing: rip  
  Default version control: send version 2, receive version 2  
    Interface          Send  Recv  Triggered RIP  Key-chain  
  FastEthernet0/0      2     2  
  FastEthernet0/1      2     2  
  Serial0/2            2     2  
  Automatic network summarization is in effect  
  Maximum path: 4  
  Routing for Networks:  
    10.0.0.0  
  Routing Information Sources:  
    Gateway           Distance      Last Update  
    10.0.123.242       120           00:00:06  
    10.0.123.246       120           00:00:23  
  Distance: (default is 120)  
R1#
```

这是实验5中Part 1在路由器1上配置RIP协议，通过“show ip protocols”命令查看路由器上路由协议运行情况。可以看到路由表每30秒更新一次；无效时间(Invalid)设置为180秒，抑制定时器设置为180秒，清除定时器设置为240秒。

每对一个接口配置完其IP地址，请别忘记输入“no shutdown”

Area 0

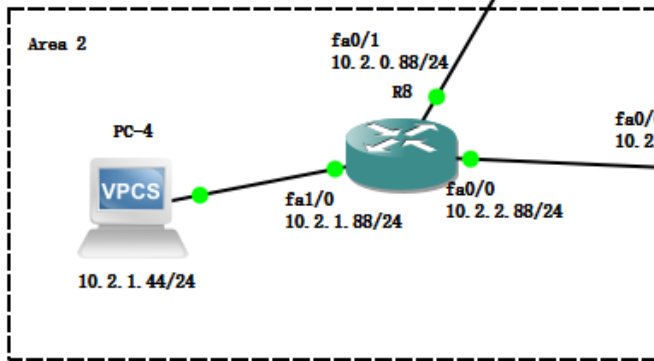
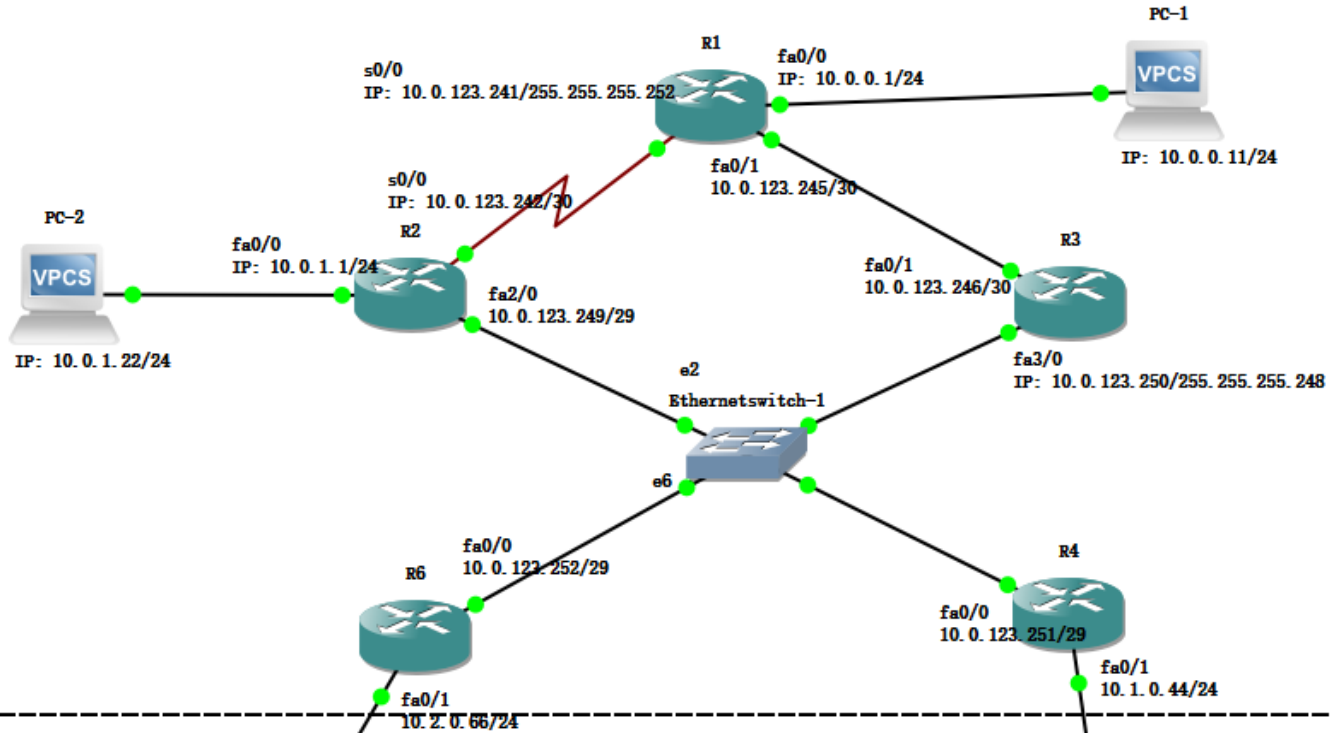

Area 1

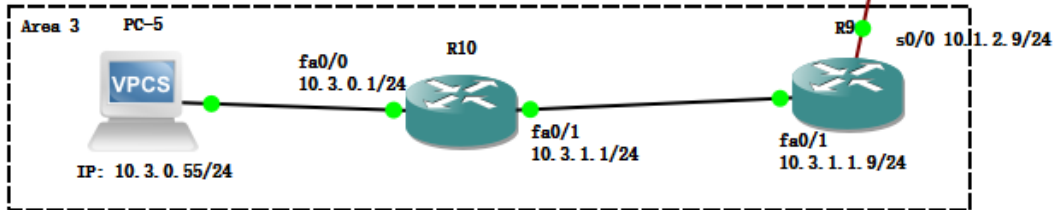
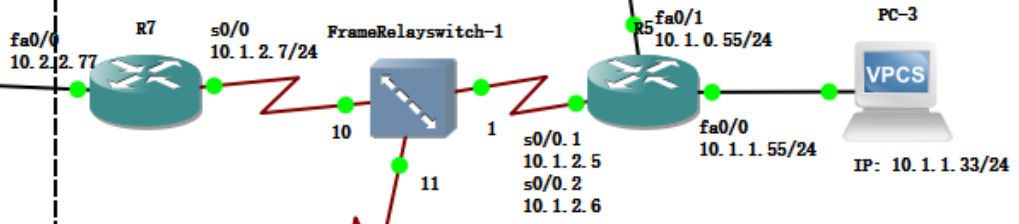

Lab5 Topology

RIP 路由协议 (IV)

Lab5New - GNS3

File Edit View Control Node Annotate Tools Help

R1

```
R1#w
*Mar 1 01:38:45.527: %SYS-5-CONFIG_I: Configured from console by console
R1#w
Building configuration...
[OK]
R1#show ip route
Codes: C - connected, S - static, R - RIP, M - mobile, B - BGP
D - EIGRP, EX - EIGRP external, O - OSPF, IA - OSPF inter area
N1 - OSPF NSSA external type 1, N2 - OSPF NSSA external type 2
E1 - OSPF external type 1, E2 - OSPF external type 2
I - IS-IS, su - IS-IS summary, L1 - IS-IS level-1, L2 - IS-IS level-2
ia - IS-IS inter area, * - candidate default, U - per-user static route
o - ODR, P - periodic downloaded static route

Gateway of last resort is not set

  10.0.0.0/8 is variably subnetted, 5 subnets, 3 masks
    C   10.0.0.0/24 is directly connected, FastEthernet0/0
    R   10.0.1.0/24 [120/1] via 10.0.123.242, 00:00:09, Serial0/0
    C   10.0.123.240/30 is directly connected, Serial0/0
    C   10.0.123.244/30 is directly connected, FastEthernet0/1
    R   10.0.123.248/29 [120/1] via 10.0.123.242, 00:00:09, Serial0/0

R1#
```

R2

```
R2#w
*Mar 1 01:37:28.199: %SYS-5-CONFIG_I: Configured from console by console
R2#w
Building configuration...
[OK]
R2#show ip route
Codes: C - connected, S - static, R - RIP, M - mobile, B - BGP
D - EIGRP, EX - EIGRP external, O - OSPF, IA - OSPF inter area
N1 - OSPF NSSA external type 1, N2 - OSPF NSSA external type 2
E1 - OSPF external type 1, E2 - OSPF external type 2
I - IS-IS, su - IS-IS summary, L1 - IS-IS level-1, L2 - IS-IS level-2
ia - IS-IS inter area, * - candidate default, U - per-user static route
o - ODR, P - periodic downloaded static route

Gateway of last resort is not set

  10.0.0.0/8 is variably subnetted, 5 subnets, 3 masks
    R   10.0.0.0/24 [120/1] via 10.0.123.241, 00:00:26, Serial0/0
    C   10.0.1.0/24 is directly connected, FastEthernet0/0
    C   10.0.123.240/30 is directly connected, Serial0/0
    R   10.0.123.244/30 [120/1] via 10.0.123.250, 00:00:21, FastEthernet2/0
    R   10.0.123.248/29 [120/1] via 10.0.123.241, 00:00:26, Serial0/0

R2#
```

R3

```
R3(config)#exit
R3#wr
*Mar 1 01:24:40.467: %SYS-5-CONFIG_I: Configured from console by console
R3#w
Building configuration...
[OK]
R3#show ip route
Codes: C - connected, S - static, R - RIP, M - mobile, B - BGP
D - EIGRP, EX - EIGRP external, O - OSPF, IA - OSPF inter area
N1 - OSPF NSSA external type 1, N2 - OSPF NSSA external type 2
E1 - OSPF external type 1, E2 - OSPF external type 2
I - IS-IS, su - IS-IS summary, L1 - IS-IS level-1, L2 - IS-IS level-2
ia - IS-IS inter area, * - candidate default, U - per-user static route
o - ODR, P - periodic downloaded static route

Gateway of last resort is not set

  10.0.0.0/8 is variably subnetted, 5 subnets, 3 masks
    R   10.0.0.0/24 [120/2] via 10.0.123.249, 00:00:05, FastEthernet3/0
    R   10.0.1.0/24 [120/1] via 10.0.123.249, 00:00:05, FastEthernet3/0
    R   10.0.123.240/30 [120/1] via 10.0.123.249, 00:00:05, FastEthernet3/0
    C   10.0.123.244/30 is directly connected, FastEthernet0/1
    C   10.0.123.248/29 is directly connected, FastEthernet3/0

R3#
```

Topology Summary

Node	Console
Ethernetswitch-1	telnet 192.168.199.12...
FrameRelayswitch-1	none
PC-1	telnet 192.168.199.12...
PC-2	telnet 192.168.199.12...
PC-3	telnet 192.168.199.12...
PC-4	telnet 192.168.199.12...
PC-5	telnet 192.168.199.12...
R1	telnet 192.168.199.12...
R2	telnet 192.168.199.12...

PC-1

VPCS

R3

10.1.0.44/24

fa0/1

10.1.0.55/24

4 warnings

在此键入进行搜索

17:26 2023/11/21

路由协议

- 生成路由表项通常有两种方法：手工静态设置和动态路由协议生成。
- 动态路由协议主要包括：
 - RIP (Routing Information Protocol)
 - **OSPF (Open Shortest Path First,开放式最短路径优先协议)**
 - IS-IS (Intermediate System to Intermediate System)
 - BGP(Border Gateway Protocol)

OSPF 路由协议

- The Internet is made up of a large number of independent networks or ASes (Autonomous Systems) that are operated by different organizations, usually a company, university, or ISP.
 - Intra-domain Routing: inside of its own network, an organization can use its own algorithm for internal routing.
 - Interior gateway protocol, example: **OSPF** (Open Shortest Path First)
 - Inter-domain Routing: **all networks must use the same inter-domain routing protocol.**
 - Exterior gateway protocol, example: **BGP** (Border Gateway Protocol)

OSPF路由协议

- Distance vector routing — RIP
 - The **distributed Bellman-Ford algorithm**
 - Works well in small systems, but less well as networks get larger.
 - Suffers from **the count-to-infinity problem**
- Link state routing — OSPF
 - **Broadcast** link state packets to all other nodes in the network
 - Run the well known **Dijkstra's algorithm** at each node individually
 - Oscillation

OSPF Cost Table

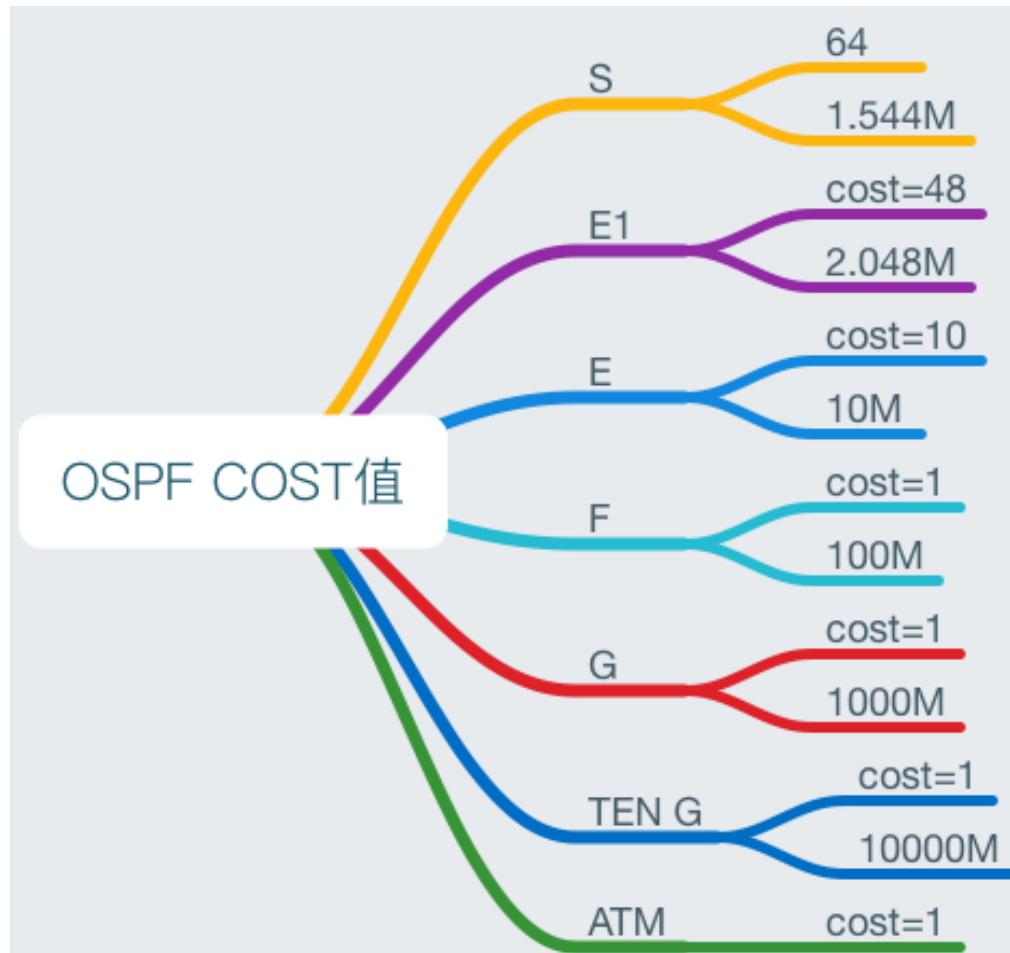

The higher data rate, the lower cost of the channel.

OSPF

- Many of the ASes in the Internet are themselves large and nontrivial to manage.
- To work at this scale, OSPF allows an AS to be divided into **numbered areas**, where an area is a network or a set of contiguous networks.
 - An area is a generalization of an individual network.
 - Outside an area, its destinations are visible but not its topology.
 - Routers that lie wholly within an area are called **internal routers**.
- **Every AS has a backbone area**, called **area 0**.
 - The routers in this area are called **backbone routers**.
 - All areas are connected to the backbone, possibly by *tunnels*, so it is possible to go from any area in the AS to any other area in the AS via the backbone.

OSPF

- Each router that is connected to two or more areas is called **an area border router** (ABR). It must also be part of the backbone.
 - The job of an area border router is to summarize the destinations in one area and to inject this summary into the other areas to which it is connected.
 - This summary includes cost information but not all the details of the topology within an area.
 - If there is only one border router out of an area, even the summary does not need to be passed. This kind of area is called **a stub area**.
- **An AS boundary router** injects routes to external destinations on other ASes into the area.
 - The external routers then appear as destinations that can be reached via the AS boundary router with some cost.

OSPF

- Each router within an area has the same link state database and runs the same shortest path algorithm.
- **An area border router(ABR)** needs the databases for all the areas to which it is connected and must run the shortest path algorithm for each area *separately*.
- Routers to external destinations may include the external cost from the AS boundary router over the external path.
- It is inefficient to have every router on a LAN talk to every other router on the LAN.
 - To avoid this situation, one router is elected as **the designed router**. It acts as the single node that represents the LAN.
 - **A backup designed router** is always kept up to date to ease the transition should the primary designed router crash and need to be replaced immediately.

OSPF路由协议

- 大型的OSPF网络使用分段设计原则，多个区域连接到一个主干区域上。
- OSPF选择所有路径中到达目的地最短的路径，并将此最短路径放入自己的路由表中。
- OSPF建立自己的路由表之前，它必须与其相邻的实体建立链接。OSPF相互告知它们自己的连接(或链路)状态，区域内的路由器处理链路状态信息，建立一个链路状态数据库(拓扑数据库)，一个链路状态数据库对应于一个有向图，每个路由器在图中有一个顶点相对应，路由器的每个接口在图中也有一条边相对应。
- 带有多个接口的路由器可以加入多个区域，这种路由器称为区域边界路由器(ABR, Area Boundary Router)，它会为每个区域维护一个单独的拓扑结构，即为每个区域维护一个单独的链路状态数据库。
- 在一个区域内，每台路由器以自己为树根，把其数据库(包含本区域内的所有链路)转换为有向图，在有向图上运行**最短路径优先算法**(SPF, Shortest Path First)，得到本区域内的最短通路树，确定最佳路径加入路由选择表中。

OSPF路由协议——邻接关系

- 由于OSPF路由器之间需要有**邻接关系**才能共享路由选择信息。所以在广播网络中，路由器将试图在它所连接的每个IP子网上，与至少一个路由器建立邻接关系。如果和所有的邻居路由器建立邻接关系，开销可能会很大。为了避免这种开销，OSPF路由器会选举**指定路由器**(Designated Router, **DR**)和**备份指定路由器**(Backup Designated Router, **BDR**)，作为路由信息交换的集中点。
- OSPF以组播地址224.0.0.5和224.0.0.6发送数据包，其中DR和BDR向其他路由设备发包时用224.0.0.5，而其他路由器向DR和BDR发包时用224.0.0.6。^[4]
- DR不是人为指定的，而是由本网段中所有的路由器共同选举出来的。选举是根据优先级，路由器ID等因素进行的。
 - DR和BDR的选举是通过hello协议实现的。每个网络分段上的hello数据包通过IP组播交换的。^[4]

OSPF路由协议 — Loopback

- **Loopback接口**（回环接口）是路由器里面的一个**逻辑接口**。逻辑接口是指能够实现数据交换功能，但是物理上不存在、需要通过配置建立的接口。**Loopback接口一旦被创建，其物理状态和链路协议状态永远是Up，即使该接口上没有配置IP地址。**
- 一些动态路由协议要求路由器必须有**Router ID**，它是一台**路由器在自治系统中的唯一标识**。例如，OSPF和BGP在**没有手工配置Router ID时，系统需要从本地接口的IP地址中选一个最大的IP地址作为Router ID**。如果选择的是物理接口的IP地址，当这个物理接口状态变为Down时，系统也不会重新选择Router ID，除非这个被选择的IP地址被删除。**因此建议使用Loopback接口的IP地址作为路由器的Router ID。因为Loopback接口稳定，它一直都处于Up状态。**

OSPF路由协议

- OSPF路由器与邻居建立链接后，将邻居路由器的信息记录在邻接数据库(Adjacency Database)中。邻接数据库以表格的形式列出此路由器的“邻接路由器”以及这些“邻接路由器”的详细信息。
- 注意在广播网络和非广播多路访问NBMA (Non-Broadcast Multiple Access)网络中，“邻接”关系和“邻居”关系是有所区别的。当一个以太网中选取了DR和BDR后，以太网中各个路由器与DR和BDR是邻接关系，发送链路状态信息，而与除DR和BDR以外的路由器是邻居关系，不是邻接关系，不直接发送链路状态信息。
 - 邻居关系和邻接关系是不同！

OSPF路由协议

- 两个路由器建立邻接关系过程中的OSPF状态
 - 1. Down (停止)状态
 - 2. INIT (初始)状态
 - 路由器以固定的时间间隔(通常是10秒)从OSPF接口发送一个呼叫包(Hello), 并且等待其邻居的响应。呼叫包被发送到多播IP地址224.0.0.5 (LAN上所有的OSPF路由器)。当一个接口收到第一个呼叫包后, 路由器进入INIT状态。
 - 3. Two-Way (双向)状态
 - 当一台路由器A收到邻居路由器B的呼叫包后, A发出的呼叫包中会写上路由器B的ID, 当路由器B看到它自己出现在A的呼叫包中时, B就认为自己与A建立了双向邻居关系。
 - Two-way状态关系中的路由器之间不能共享路由信息。
 - B是否应当与A建立邻接关系, 要看下面条件之一是否满足, 如果满足就建立邻接关系。
 - B与A之间是点到点链路或虚链路
 - B和A之一是DR
 - B和A之一是BDR

OSPF路由协议

- 两个路由器建立邻接关系过程中的OSPF状态
 - 4. ExStart (准启动)状态
 - 5. ExChange (交换)状态
 - 6. Loading (加载)状态
 - 7. Full Adjacency (全邻接)状态

OSPF路由协议 — Router ID

- 一台路由器如果要运行OSPF协议，必须存在Router ID。
- 手工给路由器配置ID号命令：
 - Router(config-router)#router-id x1.x2.x3.x4
- 如果没有配置ID号，系统会从当前接口的IP地址中自动选择一个作为路由器的ID号，**一般会从所有活动接口中选择一个最大的IP地址作为它的ID。**
- 如果该路由器配置了**Loopback**接口，则以Loopback接口的IP地址作为路由器的ID号。

OSPF路由协议

- 配置OSPF协议命令：
 - Router(config)# router ospf process-id (*process-id*是指本地路由器的一个进程号)
 - 这个进程号区分同一台路由器上的多个OSPF进程。其进程id号的取值范围是1~65535。一个路由器上可以运行多个OSPF进程，它们的进程号必须不同。进程号只有局部意义，与其他路由器的进程可以相同也可以不同。
 - Router(config-router)#network address wildcard-mask area area-id (其中*address*是主机号为0的网络地址，即子网地址；而*wildcard-mask*的值为1的那些比特位对应该子网的主机号部分host portion，值为0的那些比特位对应该*address*字段的网络号或子网号部分。 *wildcard-mask*为通配符，是网络掩码的反码。)
- Example:
 - Router(config)# router ospf 1 (进入OSPF设置状态，在路由器没有任何接口激活的情况下，它没有路由器ID，因而不能启动OSPF协议，本命令输入可能会失败。这时可以给它配置Loopback接口并设定一个接口IP地址，以解决问题)
 - Router(config)#interface loopback 0
 - Router(config-if)#ip address 10.0.20.1 255.255.255.255
 - Router(config)# router ospf 1
 - Router(config-router)#network 192.168.11.0 0.0.0.255 area 0
 - Router# show interface loopback 0 (查看回环配置情况)

OSPF路由协议---R1

Lab5New - GNS3

File Edit View Control Node Annotate Tools Help

每对一个接口配置完其IP地址, 请别忘了输入“no shutdown”

```
R1#show ip interface brief
R1#show ip route
R1#show ip ospf neighbor
```

```
R1#config t
Enter configuration commands, one per line. End with CNTL/Z.
R1(config)#no router rip
R1(config)#exit
R1#
*Mar 1 02:19:59.815: %SYS-5-CONFIG_I: Configured from console by console
R1#config t
Enter configuration commands, one per line. End with CNTL/Z.
R1(config)#router ospf 1212
R1(config-router)#network 10.0.0.0 0.0.255.255 area 0
R1(config-router)#exit
R1(config)#exit
R1#wr
*Mar 1 02:23:00.287: %SYS-5-CONFIG_I: Configured from console by console
R1#write
Building configuration...
[OK]
R1#
```

Topology Summary

Node	Console
Ethernetswitch-1	telnet 192.168.199.12...
FrameRelayswitch-1	none
PC-1	telnet 192.168.199.12...
PC-2	telnet 192.168.199.12...
PC-3	telnet 192.168.199.12...
PC-4	telnet 192.168.199.12...
PC-5	telnet 192.168.199.12...
R1	telnet 192.168.199.12...
R2	telnet 192.168.199.12...
R3	telnet 192.168.199.12...
R4	telnet 192.168.199.12...
R5	telnet 192.168.199.12...
R6	telnet 192.168.199.12...
R7	telnet 192.168.199.12...
R8	telnet 192.168.199.12...
R9	telnet 192.168.199.12...
R10	telnet 192.168.199.12...

Servers Summary

- DESKTOP-EODNB7E CPU 0.6%, RAM 38.6%
- GNS3 VM (GNS3 VM) CPU 15.5%, RAM 96.5%

Console

GNS3 management console.
Running GNS3 version 2.1.9 on Windows (64-bit) with Python 3.6.6 Qt 5.8.0 and PyQt 5.8.
Copyright (c) 2006-2023 GNS3 Technologies.
Use Help -> GNS3 Doctor to detect common issues.

4 warnings

OSPF路由协议---R1, R2, R3

Lab5New - GNS3

File Edit View Control Node Annotate Tools Help

Topology Summary

Node	Console
Ethernetswitch-1	telnet 192.168.199.12...
FrameRelayswitch-1	none
PC-1	telnet 192.168.199.12...
PC-2	telnet 192.168.199.12...
PC-3	telnet 192.168.199.12...
PC-4	telnet 192.168.199.12...
PC-5	telnet 192.168.199.12...
PC-6	telnet 192.168.199.12...

```
R1
[OK]
R1#
*Mar 1 02:32:09.391: %OSPF-5-ADJCHG: Process 1212, Nbr 10.0.20.1 on Serial0/0 from LOADING to FULL, Loading Done
R1#
*Mar 1 02:33:23.143: %OSPF-5-ADJCHG: Process 1212, Nbr 10.0.30.1 on FastEthernet0/1 from LOADING to FULL, Loading Done
R1#show ip ospf database

OSPF Router with ID (10.0.123.245) (Process ID 1212)

Router Link States (Area 0)

Link ID        ADV Router    Age           Seq#           Checksum Link
10.0.20.1      10.0.20.1    1512         0x80000003    0x00E3B4 5
10.0.30.1      10.0.30.1    1416         0x80000002    0x003D91 2
10.0.123.245   10.0.123.245 1507         0x80000004    0x001557 4

Net Link States (Area 0)

Link ID        ADV Router    Age           Seq#           Checksum
10.0.123.245   10.0.123.245 1507         0x80000002    0x00DDC2
10.0.123.249   10.0.20.1    1512         0x80000002    0x00FA5E
R1#

R2
*Mar 1 02:30:25.107: %SYS-5-CONFIG_I: Configured from console by console
R2#write
Building configuration...
[OK]
R2#
*Mar 1 02:31:33.051: %OSPF-5-ADJCHG: Process 1212, Nbr 10.0.30.1 on FastEthernet0/1 from LOADING to FULL, Loading Done
R2#show ip ospf database

OSPF Router with ID (10.0.20.1) (Process ID 1212)

Router Link States (Area 0)

Link ID        ADV Router    Age           Seq#           Checksum Link count
10.0.20.1      10.0.20.1    210          0x80000004    0x00E1B5 5
10.0.30.1      10.0.30.1    1918         0x80000002    0x003D91 2
10.0.123.245   10.0.123.245 2009         0x80000004    0x001557 4

Net Link States (Area 0)

Link ID        ADV Router    Age           Seq#           Checksum
10.0.123.245   10.0.123.245 2009         0x80000002    0x00DDC2
10.0.20.1      10.0.20.1    210          0x80000003    0x00F85F
R2#

R3
R3(config-router)#exit
R3(config)#exit
R3#
*Mar 1 02:18:30.075: %SYS-5-CONFIG_I: Configured from console by console
R3#write
Building configuration...
[OK]
R3#show ip ospf database

OSPF Router with ID (10.0.30.1) (Process ID 1212)

Router Link States (Area 0)

Link ID        ADV Router    Age           Seq#           Checksum Link count
10.0.20.1      10.0.20.1    357          0x80000004    0x00E1B5 5
10.0.30.1      10.0.30.1    67           0x80000003    0x003B92 2
10.0.123.245   10.0.123.245 132          0x80000005    0x001358 4

Net Link States (Area 0)

Link ID        ADV Router    Age           Seq#           Checksum
10.0.123.245   10.0.123.245 132          0x80000003    0x00DBC3
10.0.123.249   10.0.20.1    357          0x80000003    0x00F85F
R3#
```

fa0/1
10.1.0.44/24

fa0/1
10.1.0.55/24

Console

GNS3 man...
Running 10.0.123.245
Copyright 10.0.123.249
Use Help R2#

4 warnings

在此键入进行搜索

14°C

19:05
2023/11/21

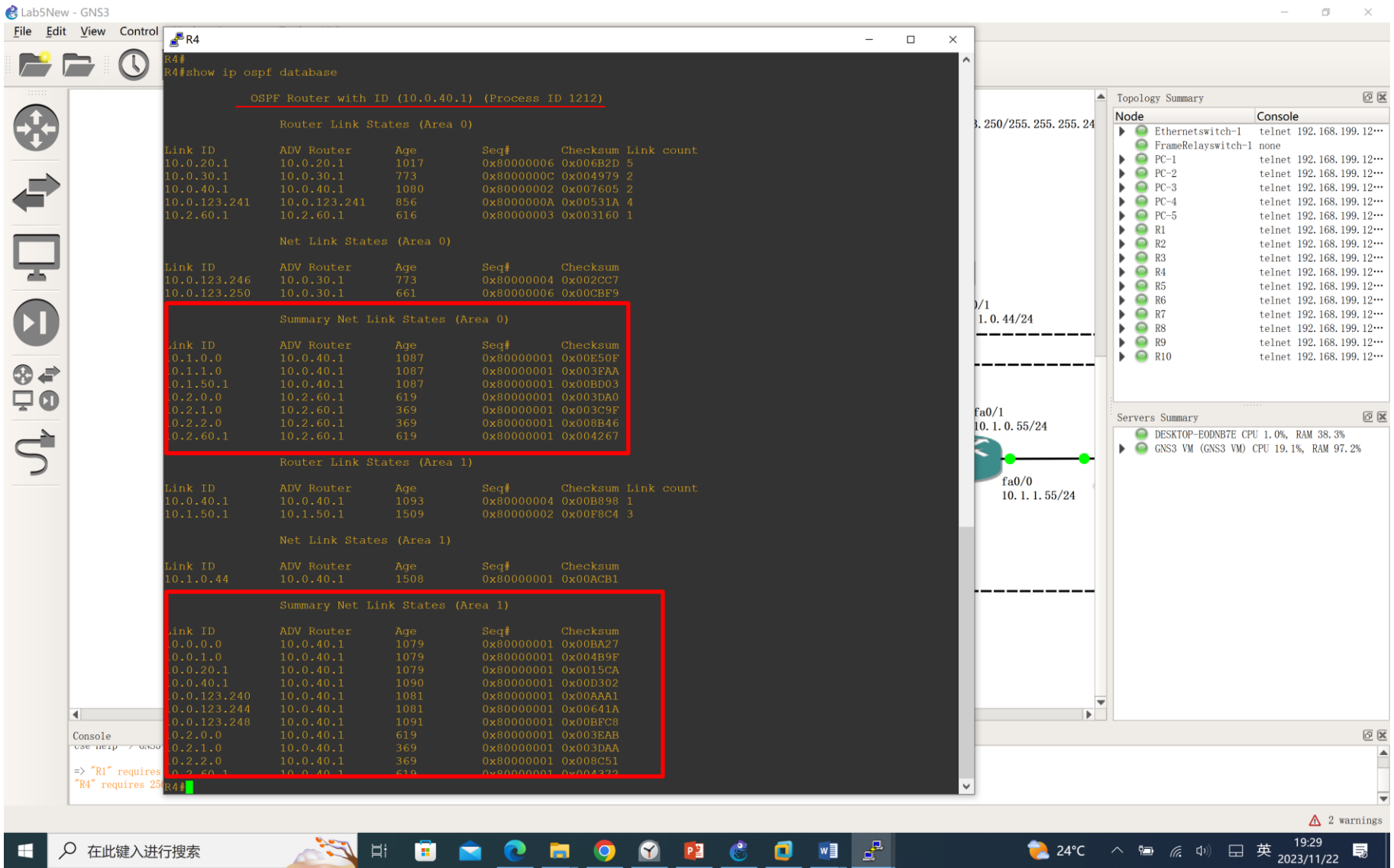

由于R4是区域边界路由器（Area Border Router，简称ABR），所以对区域内的链路进行了汇聚，然后以区域间路由的形式向其他区域进行链路状态通告（LSA）。由于在路由器R4上配置了回环，因此路由器的ID就是R4所配置回环的IP地址10.0.40.1。

The screenshot shows a GNS3 network simulation with three OSPF areas:

- Area 0:** Contains router R6 (IP: 10.0.1.22/24) and router R8 (IP: 10.2.1.88/24). R6 is connected to R8 via fa0/0 (10.2.2.88/24) and fa0/1 (10.2.0.88/24).
- Area 2:** Contains router R8 and PC-4 (IP: 10.2.1.44/24). R8 is connected to PC-4 via fa1/0 (10.2.1.88/24).
- Area 3:** Contains router R10 (IP: 10.3.0.1/24) and PC-5 (IP: 10.3.0.55/24). R10 is connected to PC-5 via fa0/0 (10.3.0.1/24).

The terminal window for R6 shows the following OSPF output:

```

R6#show ip ospf database

OSPF Router with ID (10.2.60.1) (Process ID 1212)

Router Link States (Area 0)

Link ID        ADV Router    Age           Seq#          Checksum Link count
-----
10.0.20.1     10.0.20.1     1676         0x80000006   0x006B2D 5
10.0.30.1     10.0.30.1     1433         0x8000000C   0x004979 2
10.0.40.1     10.0.40.1     1741         0x80000002   0x007605 2
10.0.123.241  10.0.123.241 1515         0x8000000A   0x00531A 4
10.2.60.1     10.2.60.1     1273         0x80000003   0x003160 1

Net Link States (Area 0)

Link ID        ADV Router    Age           Seq#          Checksum
-----
10.0.123.246  10.0.30.1     1433         0x80000004   0x002C67
10.0.123.250  10.0.30.1     1320         0x80000006   0x00C6F9

Summary Net Link States (Area 0)

Link ID        ADV Router    Age           Seq#          Checksum
-----
0.1.0.0       10.0.40.1     1747         0x80000001   0x00E50F
0.1.1.0       10.0.40.1     1747         0x80000001   0x003FAA
0.1.50.1      10.0.40.1     1747         0x80000001   0x00BD03
0.2.0.0       10.2.60.1     1274         0x80000001   0x003DA0
0.2.1.0       10.2.60.1     1024         0x80000001   0x003C9F
0.2.2.0       10.2.60.1     1024         0x80000001   0x008B46
0.2.60.1      10.2.60.1     1274         0x80000001   0x004267

Router Link States (Area 2)

Link ID        ADV Router    Age           Seq#          Checksum Link count
-----
10.2.2.88     10.2.2.88     1030         0x80000002   0x00C69C 3
10.2.60.1     10.2.60.1     1029         0x80000002   0x001589 2

Net Link States (Area 2)

Link ID        ADV Router    Age           Seq#          Checksum
-----
10.2.0.66     10.2.60.1     1029         0x80000001   0x004CA6

Summary Net Link States (Area 2)

Link ID        ADV Router    Age           Seq#          Checksum
-----
10.0.0.0      10.2.60.1     1279         0x80000001   0x001EAD
10.0.1.0      10.2.60.1     1279         0x80000001   0x00AE26
10.0.20.1     10.2.60.1     1279         0x80000001   0x007851
10.0.40.1     10.2.60.1     1281         0x80000001   0x009B1A
10.0.123.240  10.2.60.1     1283         0x80000001   0x000E28
10.0.123.244  10.2.60.1     1283         0x80000001   0x00C7A0
10.0.123.248  10.2.60.1     1283         0x80000001   0x0023F4
10.1.0.0      10.2.60.1     1283         0x80000001   0x00AD27
10.1.1.0      10.2.60.1     1283         0x80000001   0x0007C2
10.1.50.1     10.2.60.1     1283         0x80000001   0x00851B
  
```

同样R6是区域边界路由器（简称ABR），所以对区域内的链路进行了汇聚，然后以区域间路由的形式向其他区域进行链路状态通告（LSA）。由于在路由器R6上配置了回环，因此路由器的ID就是R6所配置回环的IP地址10.2.60.1。

Lab5New - GNS3

File Edit View Control Node Annotate Tools Help

Topology Summary

Node	Console
Ethernetswitch-1	telnet 192.168.199.12...
FrameRelayswitch-1	none
PC-1	telnet 192.168.199.12...
PC-2	telnet 192.168.199.12...
PC-3	telnet 192.168.199.12...
PC-4	telnet 192.168.199.12...
PC-5	telnet 192.168.199.12...
R1	telnet 192.168.199.12...
R2	telnet 192.168.199.12...
R3	telnet 192.168.199.12...
R4	telnet 192.168.199.12...
R5	telnet 192.168.199.12...
R6	telnet 192.168.199.12...
R7	telnet 192.168.199.12...
R8	telnet 192.168.199.12...
R9	telnet 192.168.199.12...
R0	telnet 192.168.199.12...

```

PC-4
NAME       : PC-4[1]
IP/MASK    : 10.2.1.44/24
GATEWAY    : 10.2.1.88
DNS        :
MAC        : 00:50:79:66:68:03
LPORT     : 10078
RHOST:PORT : 127.0.0.1:10079
MTU       : 1500

PC-4> ping 10.0.1.22
10.0.1.22 icmp_seq=1 timeout
10.0.1.22 icmp_seq=2 timeout
84 bytes from 10.0.1.22 icmp_seq=3 ttl=61 time=53.421 ms
84 bytes from 10.0.1.22 icmp_seq=4 ttl=61 time=45.030 ms
84 bytes from 10.0.1.22 icmp_seq=5 ttl=61 time=57.177 ms

PC-4> traceroute 10.0.1.22
trace to 10.0.1.22, 8 hops max, press Ctrl+C to stop
 1  10.2.1.88      14.806 ms  14.677 ms  15.063 ms
 2  10.2.0.66     47.671 ms  44.819 ms  46.714 ms
 3  10.0.123.249  77.184 ms  79.205 ms  92.449 ms
 4  *10.0.1.22   92.795 ms (ICMP type:3, code:3, Destination port unreachable)

PC-4>

```

Console

```

=> "R1" requires 256MB of RAM to run but there is only 195MB - 90.2% of RAM left on "gns3vm"
"R4" requires 256MB of RAM to run but there is only 226MB - 88.7% of RAM left on "gns3vm"

```

X: -529.0 Y: -293.0 Z: -1.0

在此键入进行搜索

17°C

19:50

2023/11/22

2 warnings

在PC4上运行“tracer 10.0.1.22”，跟踪一下到PC2中间经过的路由器，看一下ICMP最后返回的error message中type = 3, code =3, Destination Port Unreachable。

OSPF路由协议

- 查看OSPF数据库
 - Router# show ip ospf database
- 查看OSPF路由器端口（接口）信息
 - Router# show ip ospf interface
- 查看OSPF邻居信息
 - Router# show ip ospf neighbor
 - Router# show ip ospf neighbor detail
- 查看区域边界路由器(ABR)信息
 - Router# show ip ospf border-router
- OSPF事件调试
 - Router# debug ip ospf events

配置Frame Relay数据链路 (I)

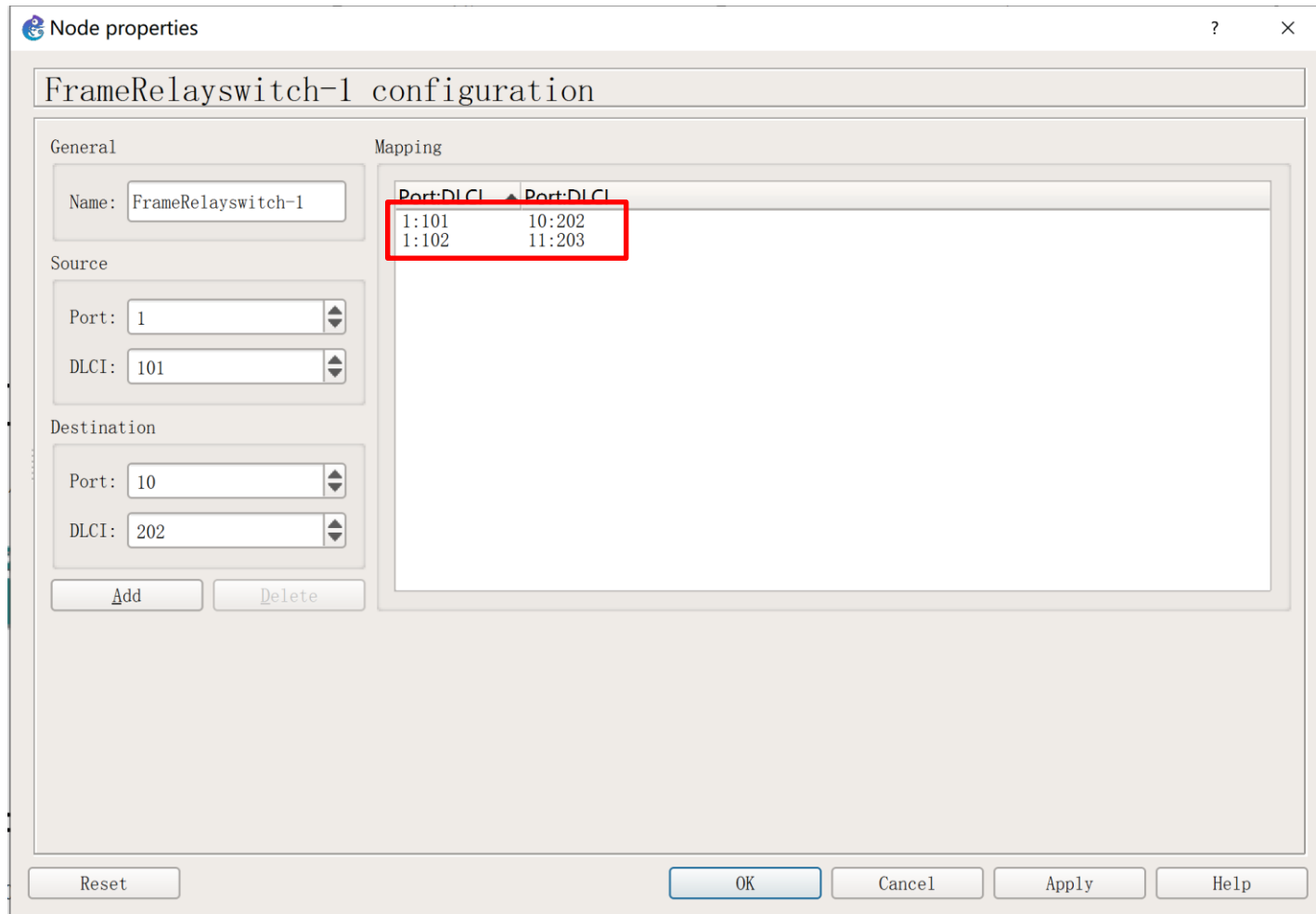

注意这里GNS3指导手册中有个坑：从网络拓扑图可以看到，R5的串口s0/0连接frame-relay交换机，这个串口需要设置两个子接口，红框中上下两行中source port number必须一致，不同的是DLCI（数据链路连接标识符）。要“Add”两次：第一次设置按照红框中第一行参数设置，第二次按照第二行参数设置。

配置Frame Relay数据链路 (II)

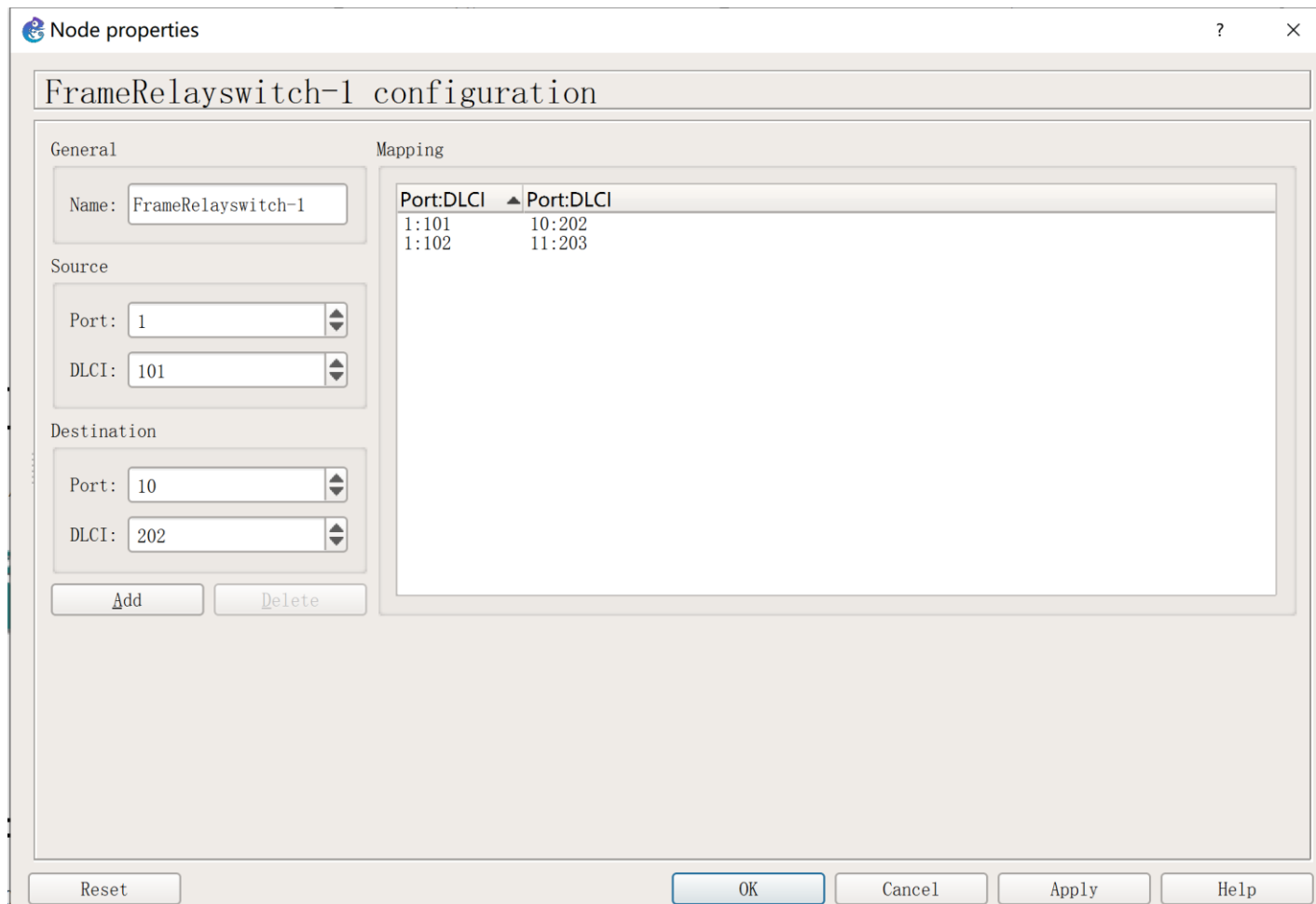

Lab5中第19, 20步配置Frame Relay数据链路: 路由器R5的串口s0/0的两个子接口DLCI分别对应101和102。路由器R7的串口s0/0连着帧中继10号端口, 路由器R9的串口s0/0连着帧中继11号端口。注意路由器R5, R7和R9串口的IP地址设置必须在同一子网内, 因为他们是通过交换机连着的。

配置Frame Relay数据链路 (III)

- 由于R5-R7采用的是点对点Frame Relay连接，只有R5的1个子接口地址可以ping通。注意R5的串口s0/0两个子接口分别配置了10.1.2.5/24和10.1.2.6/24 IP地址。

```
R7#  
R7#ping 10.1.2.5  
-----  
Type escape sequence to abort.  
Sending 5, 100-byte ICMP Echos to 10.1.2.5, timeout is 2 seconds:  
!!!!  
Success rate is 100 percent (5/5), round-trip min/avg/max = 1/4/12 ms  
R7#ping 10.1.2.6  
-----  
Type escape sequence to abort.  
Sending 5, 100-byte ICMP Echos to 10.1.2.6, timeout is 2 seconds:  
.....  
Success rate is 0 percent (0/5)  
R7#
```

配置Frame Relay数据链路 (IV)

- R5的串口s0/0有两个子接口，IP地址分别为10.1.2.5/24和10.1.2.6/24；R7的串口s0/0的IP地址为10.1.2.7/24，R9的串口s0/0的IP地址为10.1.2.9/24，是在同一网段内的。但是由于数据链路不是广播式，所以在没有建立点对点数据链路的情况下，是不能通信的。

```
R9#ping 10.1.2.7
Type escape sequence to abort.
Sending 5, 100-byte ICMP Echos to 10.1.2.7, timeout is 2 seconds:
.....
Success rate is 0 percent (0/5)
R9#
```

OSPF路由协议：虚链接

- **虚链接（Virtual-link）**：由于网络的拓扑结构复杂，有时无法满足每个区域必须和骨干区域直接相连的要求，为解决此问题，OSPF提出了虚链路的概念。[3]
- 虚链接是设置在两个路由器之间，这两个路由器都有一个端口与同一个非主干区域相连。虚连接被认为是属于主干区域的，在OSPF路由协议看来，虚连接两端的两个路由器被一个点对点的链路连接在一起。
 - 逻辑上的连接通道

OSPF路由协议：虚链接命令

- 在边界路由器为不同区域之间创建虚链路
 - Router(config)# router ospf process-id
 - Router(config-router)# area <area-id> virtual-link RID (RID写对方的Router ID)
- 查看虚链路建立情况
 - Router# show ip ospf virtual-links

每对一个接口配置完其IP地址，请别忘记输入“no shutdown”

Area 0

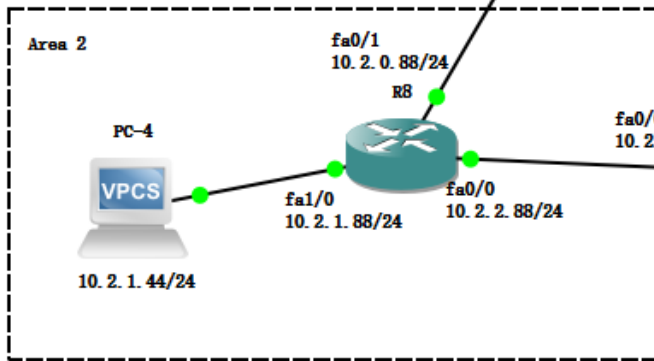
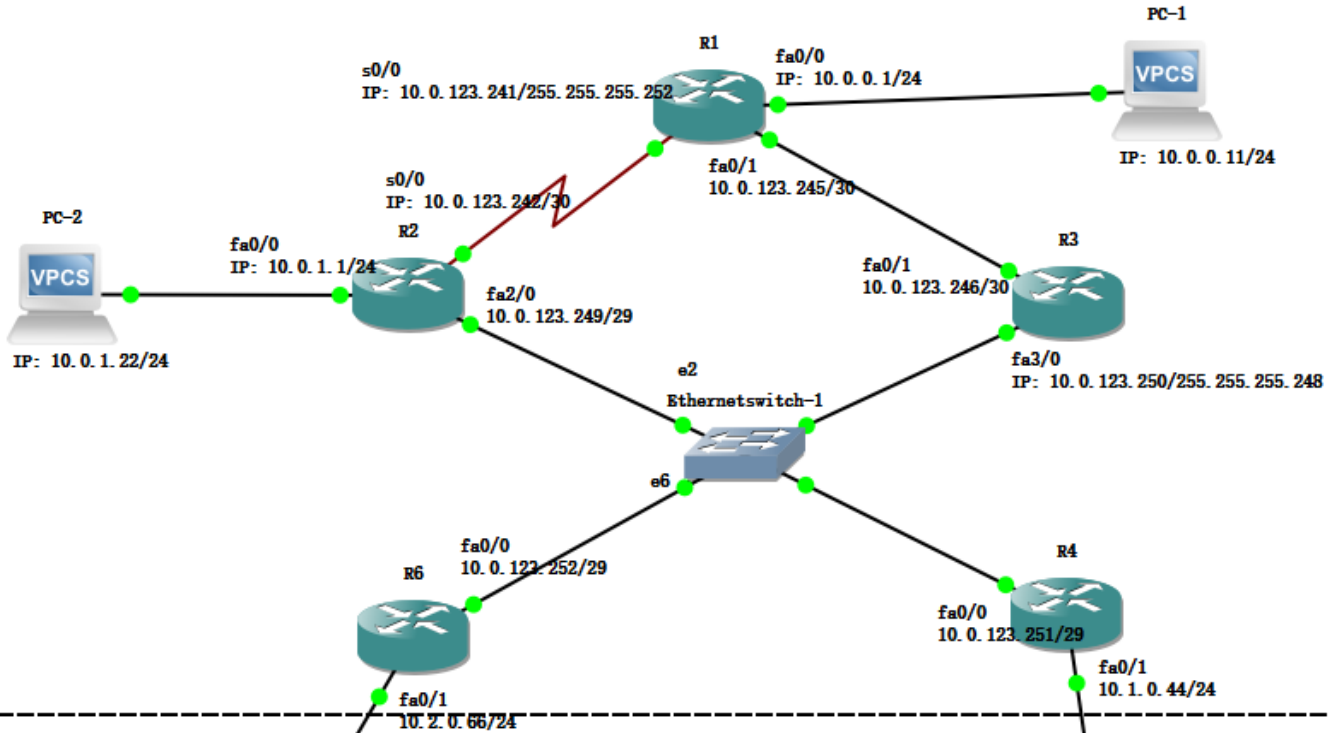

Area 1

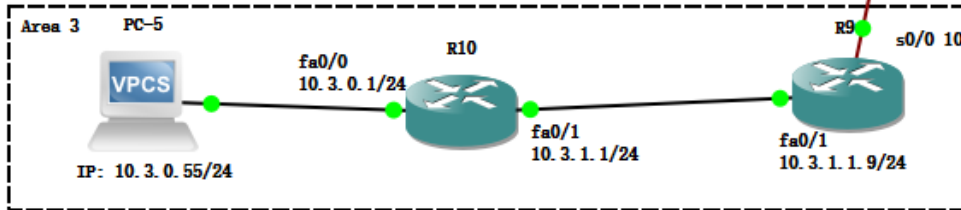
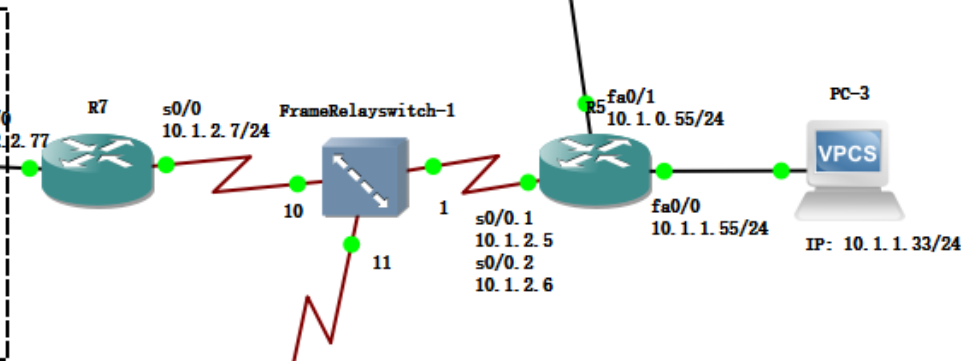

Lab5 Topology

OSPF路由协议：建立虚链路例子

- 开始的时候Area 3和主干Area 0没有直连。Lab5中第29步内容：在Area 1上的两个边界路由器R9、R4之间为Area 3和Area 0创建虚链路（命令：area <area-id> virtual-link RID），这样Area 3就能和Area 0进行路由信息交换了。其中，area-id写1，RID写对方的Router ID。
- R4配置命令：
 - R4(config)# router ospf 1212
 - R4(config-router)# area 1 virtual-link 10.3.90.1
- R9配置命令：
 - R9(config)# router ospf 1212
 - R9(config-router)# area 1 virtual-link 10.0.40.1

OSPF路由协议：建立虚链路例子

The screenshot displays the GNS3 Lab5New interface with two terminal windows and a topology diagram.

R4 Terminal Output:

```
R4#show ip ospf virtual-links
Virtual Link OSPF_VL0 to router 10.3.90.1 is up
Run as demand circuit
DoNotAge LSA allowed.
Transit area 1, via interface FastEthernet0/1, Cost of using 74
Transmit Delay is 1 sec, State POINT_TO_POINT,
Timer intervals configured, Hello 10, Dead 40, Wait 40, Retransmit 5
Hello due in 00:00:05
Adjacency State FULL (Hello suppressed)
Index 4/5, retransmission queue length 0, number of retransmission 0
First 0x0(0)/0x0(0) Next 0x0(0)/0x0(0)
Last retransmission scan length is 0, maximum is 0
Last retransmission scan time is 0 msec, maximum is 0 msec
R4#show ip ospf neighbor
```

Neighbor ID	Pri	State	Dead Time	Address	Interface
10.3.90.1	0	FULL/-	-	10.1.2.9	OSPF_VL0
10.0.20.1	1	FULL/DROTHER	00:00:38	10.0.123.249	FastEthernet0/0
10.0.30.1	1	FULL/DROTHER	00:00:38	10.0.123.250	FastEthernet0/0
10.2.60.1	1	FULL/DR	00:00:38	10.0.123.252	FastEthernet0/0
10.1.50.1	1	FULL/DR	00:00:39	10.1.0.55	FastEthernet0/1

R9 Terminal Output:

```
R9#write
Building configuration...
[OK]
R9#show ip ospf virtual-link
Virtual Link OSPF_VL0 to router 10.0.40.1 is up
Run as demand circuit
DoNotAge LSA allowed.
Transit area 1, via interface Serial0/0, Cost of using 74
Transmit Delay is 1 sec, State POINT_TO_POINT,
Timer intervals configured, Hello 10, Dead 40, Wait 40, Retransmit 5
Hello due in 00:00:00
Adjacency State FULL (Hello suppressed)
Index 1/3, retransmission queue length 0, number of retransmission 0
First 0x0(0)/0x0(0) Next 0x0(0)/0x0(0)
Last retransmission scan length is 0, maximum is 0
Last retransmission scan time is 0 msec, maximum is 0 msec
R9#show ip ospf neighbor
```

Neighbor ID	Pri	State	Dead Time	Address	Interface
10.0.40.1	0	FULL/-	-	10.1.0.44	OSPF_VL0
10.1.50.1	0	FULL/-	00:01:39	10.1.2.6	Serial0/0
10.3.1.1	1	FULL/BDR	00:00:37	10.3.1.1	FastEthernet0/1

Topology Diagram: Shows a network topology with nodes R1 through R10, a VPCS (Virtual PC) connected to PC-3, and various interfaces like fa0/0 and Serial0/0. A dashed box highlights a specific link configuration between R4 and R9.

Topology Summary:

Node	Console
Ethernetswitch-1	telnet 192.168.199.12...
FrameRelayswitch-1	none
PC-1	telnet 192.168.199.12...
PC-2	telnet 192.168.199.12...
PC-3	telnet 192.168.199.12...
PC-4	telnet 192.168.199.12...
PC-5	telnet 192.168.199.12...
R1	telnet 192.168.199.12...
R2	telnet 192.168.199.12...
R3	telnet 192.168.199.12...
R4	telnet 192.168.199.12...
R5	telnet 192.168.199.12...
R6	telnet 192.168.199.12...
R7	telnet 192.168.199.12...
R8	telnet 192.168.199.12...
R9	telnet 192.168.199.12...
R10	telnet 192.168.199.12...

Servers Summary:

- DESKTOP-EODNB7E CPU 1.7%, RAM 34.4%
- GNS3 VM (GNS3 VM) CPU 15.6%, RAM 96.8%

OSPF路由协议：路由聚合

- 路由聚合（主要作用是减少路由器上路由信息的数量）
 - Router(config)# router ospf process-id
 - Router(config-router)# area <area-id> range <ip_net> <mask>
- 实例：
 - Lab5中第31步：在R9上手工合并Area 0上的子网路由（命令：area 0 range <ip_net> <mask>，其中ip_net写成10.0.0.0，mask写成255.255.0.0，表示10.0.x.x这些网络都在area 0上）

```
R9#config t
Enter configuration commands, one per line.  End with CNTL/Z.
R9(config)#router ospf 1212
R9(config-router)#area 0 range 10.0.0.0 255.255.0.0
R9(config-router)#exit
R9(config)#exit
R9#
```

OSPF路由协议：路由聚合实例

```
R9#show ip route
Codes: C - connected, S - static, R - RIP, M - mobile, B - BGP
       D - EIGRP, EX - EIGRP external, O - OSPF, IA - OSPF inter area
       N1 - OSPF NSSA external type 1, N2 - OSPF NSSA external type 2
       E1 - OSPF external type 1, E2 - OSPF external type 2
       i - IS-IS, su - IS-IS summary, L1 - IS-IS level-1, L2 - IS-IS level-2
       ia - IS-IS inter area, * - candidate default, U - per-user static route
       o - ODR, P - periodic downloaded static route

Gateway of last resort is not set

10.0.0.0/8 is variably subnetted, 23 subnets, 5 masks
C       10.3.1.0/24 is directly connected, FastEthernet0/1
O IA    10.2.0.0/24 [110/94] via 10.1.2.6, 00:00:12, Serial0/0
O       10.3.0.0/24 [110/20] via 10.3.1.1, 00:00:12, FastEthernet0/1
O IA    10.2.1.0/24 [110/95] via 10.1.2.6, 00:00:12, Serial0/0
C       10.1.2.0/24 is directly connected, Serial0/0
O IA    10.2.2.0/24 [110/104] via 10.1.2.6, 00:00:12, Serial0/0
O       10.1.1.0/24 [110/74] via 10.1.2.6, 00:00:12, Serial0/0
O       10.0.0.0/24 [110/158] via 10.1.2.6, 00:00:13, Serial0/0
O       10.0.0.0/16 is a summary, 00:00:13, Null0
O       10.1.0.0/24 [110/74] via 10.1.2.6, 00:00:13, Serial0/0
O       10.0.1.0/24 [110/94] via 10.1.2.6, 00:00:13, Serial0/0
O       10.1.2.5/32 [110/64] via 10.1.2.6, 00:00:13, Serial0/0
O       10.1.2.7/32 [110/128] via 10.1.2.6, 00:00:16, Serial0/0
O       10.1.2.6/32 [110/64] via 10.1.2.6, 00:00:16, Serial0/0
O       10.0.20.1/32 [110/85] via 10.1.2.6, 00:00:16, Serial0/0
O       10.0.40.1/32 [110/75] via 10.1.2.6, 00:00:16, Serial0/0
O IA    10.2.60.1/32 [110/85] via 10.1.2.6, 00:00:16, Serial0/0
O       10.1.50.1/32 [110/65] via 10.1.2.6, 00:00:16, Serial0/0
O IA    10.2.70.1/32 [110/105] via 10.1.2.6, 00:00:16, Serial0/0
C       10.3.90.1/32 is directly connected, Loopback0
O       10.0.123.240/30 [110/148] via 10.1.2.6, 00:00:16, Serial0/0
O       10.0.123.244/30 [110/158] via 10.1.2.6, 00:00:16, Serial0/0
O       10.0.123.248/29 [110/84] via 10.1.2.6, 00:00:16, Serial0/0
R9#
```

Lab5中第31步内容：合并的那条路由，这条路由采用了特殊的接口 NULL0 作为下一跳。

同一区域的所有路由器的LSDB (Link-State Database)是一样的，下图就是整个实验完成后，区域Area 0中R1，R2和R3采用命令“show ip ospf database”的显示内容是一摸一样。因为OSPF采用的就是Link-State计算路由协议，同一区域内部每个路由器必须知道区域的网络拓扑图，然后才能采用Dijkstra算法计算它到其它节点的最短路径。

```

R2#show ip ospf database
      OSPF Router with ID (10.0.20.1)
  Router Link States (Area 0)
Link ID      ADV Router  Link ID      ADV Router
10.0.20.1    10.0.20.1   10.0.20.1    10.0.20.1
10.0.30.1    10.0.30.1   10.0.30.1    10.0.30.1
10.0.40.1    10.0.40.1   10.0.40.1    10.0.40.1
10.0.60.1    10.0.60.1   10.0.60.1    10.0.60.1
10.0.123.245 10.0.123.245 10.0.123.245 10.0.123.245
10.3.90.1    10.3.90.1   10.3.90.1    10.3.90.1

Net Link States (Area 0)
Link ID      ADV Router  Link ID      ADV Router
10.0.123.245 10.0.123.245 10.0.123.245 10.0.123.245
10.0.123.252 10.0.60.1   10.0.123.252 10.0.60.1

Summary Net Link States (Area 0)
Link ID      ADV Router  Link ID      ADV Router
10.1.0.0     10.0.40.1   10.1.0.0     10.0.40.1
10.1.0.0     10.3.90.1   10.1.0.0     10.3.90.1
10.1.1.0     10.0.40.1   10.1.1.0     10.0.40.1
10.1.1.0     10.3.90.1   10.1.1.0     10.3.90.1
10.1.1.0     10.3.90.1   10.1.1.0     10.3.90.1
10.1.2.5     10.0.40.1   10.1.2.5     10.0.40.1
10.1.2.5     10.3.90.1   10.1.2.5     10.3.90.1
10.1.2.6     10.0.40.1   10.1.2.6     10.0.40.1
10.1.2.6     10.3.90.1   10.1.2.6     10.3.90.1
10.1.2.6     10.3.90.1   10.1.2.6     10.3.90.1
10.1.2.7     10.0.40.1   10.1.2.7     10.0.40.1
10.1.2.7     10.3.90.1   10.1.2.7     10.3.90.1
10.1.2.7     10.3.90.1   10.1.2.7     10.3.90.1
10.1.2.9     10.0.40.1   10.1.2.9     10.0.40.1
10.1.2.9     10.3.90.1   10.1.2.9     10.3.90.1
10.1.2.9     10.3.90.1   10.1.2.9     10.3.90.1
10.1.50.1    10.0.40.1   10.1.50.1    10.0.40.1
10.1.50.1    10.3.90.1   10.1.50.1    10.3.90.1
10.2.0.0     10.0.60.1   10.2.0.0     10.0.60.1
10.2.1.0     10.0.60.1   10.2.1.0     10.0.60.1
10.2.70.1    10.0.60.1   10.2.70.1    10.0.60.1
10.2.80.1    10.0.60.1   10.2.80.1    10.0.60.1
10.2.123.240 10.0.60.1   10.2.123.240 10.0.60.1
10.3.0.0     10.3.90.1   10.3.0.0     10.3.90.1
10.3.90.1    10.3.90.1   10.3.90.1    10.3.90.1
10.3.123.240 10.3.90.1   10.3.123.240 10.3.90.1

R3#show ip ospf database
      OSPF Router with ID (10.0.30.1)
  Router Link States (Area 0)
Link ID      ADV Router  Link ID      ADV Router
10.0.20.1    10.0.20.1   10.0.20.1    10.0.20.1
10.0.30.1    10.0.30.1   10.0.30.1    10.0.30.1
10.0.40.1    10.0.40.1   10.0.40.1    10.0.40.1
10.0.60.1    10.0.60.1   10.0.60.1    10.0.60.1
10.0.123.245 10.0.123.245 10.0.123.245 10.0.123.245
10.3.90.1    10.3.90.1   10.3.90.1    10.3.90.1

Net Link States (Area 0)
Link ID      ADV Router  Link ID      ADV Router
10.0.123.245 10.0.123.245 10.0.123.245 10.0.123.245
10.0.123.252 10.0.60.1   10.0.123.252 10.0.60.1

Summary Net Link States (Area 0)
Link ID      ADV Router  Link ID      ADV Router
10.1.0.0     10.0.40.1   10.1.0.0     10.0.40.1
10.1.0.0     10.3.90.1   10.1.0.0     10.3.90.1
10.1.1.0     10.0.40.1   10.1.1.0     10.0.40.1
10.1.1.0     10.3.90.1   10.1.1.0     10.3.90.1
10.1.1.0     10.3.90.1   10.1.1.0     10.3.90.1
10.1.2.5     10.0.40.1   10.1.2.5     10.0.40.1
10.1.2.5     10.3.90.1   10.1.2.5     10.3.90.1
10.1.2.6     10.0.40.1   10.1.2.6     10.0.40.1
10.1.2.6     10.3.90.1   10.1.2.6     10.3.90.1
10.1.2.6     10.3.90.1   10.1.2.6     10.3.90.1
10.1.2.7     10.0.40.1   10.1.2.7     10.0.40.1
10.1.2.7     10.3.90.1   10.1.2.7     10.3.90.1
10.1.2.7     10.3.90.1   10.1.2.7     10.3.90.1
10.1.2.9     10.0.40.1   10.1.2.9     10.0.40.1
10.1.2.9     10.3.90.1   10.1.2.9     10.3.90.1
10.1.2.9     10.3.90.1   10.1.2.9     10.3.90.1
10.1.50.1    10.0.40.1   10.1.50.1    10.0.40.1
10.1.50.1    10.3.90.1   10.1.50.1    10.3.90.1
10.2.0.0     10.0.60.1   10.2.0.0     10.0.60.1
10.2.1.0     10.0.60.1   10.2.1.0     10.0.60.1
10.2.70.1    10.0.60.1   10.2.70.1    10.0.60.1
10.2.80.1    10.0.60.1   10.2.80.1    10.0.60.1
10.2.123.240 10.0.60.1   10.2.123.240 10.0.60.1
10.3.0.0     10.3.90.1   10.3.0.0     10.3.90.1
10.3.90.1    10.3.90.1   10.3.90.1    10.3.90.1
10.3.123.240 10.3.90.1   10.3.123.240 10.3.90.1

R1#show ip ospf database
      OSPF Router with ID (10.0.123.245) (Process ID 1212)
  Router Link States (Area 0)
Link ID      ADV Router  Age      Seq#       Checksum Link count
10.0.20.1    10.0.20.1   333      0x80000003 0x00266F 5
10.0.30.1    10.0.30.1   333      0x80000003 0x005971 2
10.0.40.1    10.0.40.1   304      0x80000003 0x009414 3
10.0.60.1    10.0.60.1   339      0x80000002 0x000834 2
10.0.123.245 10.0.123.245 337      0x80000002 0x00B2BB 4
10.3.90.1    10.3.90.1   3        (DNA)     0x80000002 0x007B50 1

Net Link States (Area 0)
Link ID      ADV Router  Age      Seq#       Checksum
10.0.123.245 10.0.123.245 337      0x80000001 0x00DFC1
10.0.123.252 10.0.60.1   334      0x80000002 0x008328

Summary Net Link States (Area 0)
Link ID      ADV Router  Age      Seq#       Checksum
10.1.0.0     10.0.40.1   374      0x80000001 0x00E50F
10.1.0.0     10.3.90.1   12       (DNA)     0x80000001 0x00F08E
10.1.1.0     10.0.40.1   340      0x80000001 0x003FAA
10.1.1.0     10.3.90.1   12       (DNA)     0x80000001 0x00E598
10.1.1.0     10.3.90.1   12       (DNA)     0x80000001 0x00E598
10.1.2.5     10.0.40.1   340      0x80000001 0x009D50
10.1.2.5     10.3.90.1   12       (DNA)     0x80000001 0x00443E
10.1.2.6     10.0.40.1   340      0x80000001 0x009359
10.1.2.6     10.3.90.1   12       (DNA)     0x80000001 0x003A47
10.1.2.6     10.3.90.1   12       (DNA)     0x80000001 0x003A47
10.1.2.7     10.0.40.1   310      0x80000001 0x000C9F
10.1.2.7     10.3.90.1   12       (DNA)     0x80000001 0x00B28D
10.1.2.7     10.3.90.1   12       (DNA)     0x80000001 0x00B28D
10.1.2.9     10.0.40.1   310      0x80000001 0x00F7B1
10.1.2.9     10.3.90.1   12       (DNA)     0x80000001 0x009925
10.1.2.9     10.3.90.1   12       (DNA)     0x80000001 0x009925
10.1.50.1    10.0.40.1   340      0x80000001 0x00BD03
10.1.50.1    10.3.90.1   12       (DNA)     0x80000001 0x0064F0
10.2.0.0     10.0.60.1   380      0x80000001 0x004D92
10.2.1.0     10.0.60.1   330      0x80000001 0x004C91
10.2.70.1    10.0.60.1   330      0x80000001 0x00ACE0
10.2.80.1    10.0.60.1   332      0x80000001 0x00D9B3
10.2.123.240 10.0.60.1   332      0x80000001 0x00E784
10.3.0.0     10.3.90.1   12       (DNA)     0x80000001 0x00BAF8
10.3.90.1    10.3.90.1   12       (DNA)     0x80000001 0x00105B
10.3.123.240 10.3.90.1   12       (DNA)     0x80000001 0x008CC7
  
```

References

- [1] 陆魁军, 计算机网络工程实践教学—基于Cisco路由器和交换机, 浙江大学出版社, 2006.
- [2] A.S. Tanenbaum, and D.J. Wetherall, Computer Networks, 5th Edition, Prentice Hall, 2011.
- [3] <https://baike.baidu.com/item/ospf%E8%99%9A%E9%93%BE%E8%B7%AF/3734784?fr=aladdin> (OSPF virtual link)
- [4] <https://www.cnblogs.com/wuguan/p/6847474.html>